

## ***INTRODUCTION***

---

The TWIF Executive takes great pleasure in providing this updated publication (updated version dated February 2021) which contains a wide range of information on the sport of tug of war as we think most people will require.

You will also find a short history of our sport which goes back to ancient times, including the more modern era of participation in our sport. As a sport we have come through many phases including the early 1900's which encompassed participation in no less than five Olympic Games. Not too many people outside tug of war realize that. The re-admission into the Olympic programme remains our ultimate objective.

For those who are thinking about joining or even starting a team or club, you will find links on our web-site [www.tugofwar-twif.org](http://www.tugofwar-twif.org) to those who will be able to assist you further. Likewise, if you live in a country where tug of war is already practised but there is not already an organized structure or Association you will find information in this booklet which should be helpful to you start your own club or to link into existing initiatives. The Tug of War International Federation officials listed within will welcome any contact and will gladly assist in any way possible with appropriate advice.

Competitors and officials will be interested in the updated rules for competition and, hopefully, in the wealth of other information contained within these pages.

We trust that everybody reading this booklet may you find it a useful resource and a means of furthering their enjoyment of what we consider a wonderful sport.



**ANTON RABE**  
President: TWIF

## **TWIF MISSION STATEMENT**

As an International Federation our mission is to provide the structure and good governance necessary for the well-being and development of the sport of tug of war throughout the world.

Our Primary Objective is to attain a sufficiently high level of excellence and universality to expedite our acceptance by the International Olympic Committee as a sport within the programme of the Olympic Games, a status held by our sport in the early years of the 20<sup>th</sup> century.

## Contents

INTRODUCTION.....	1
HISTORY OF TUG OF WAR.....	5
INTERNATIONAL TUG OF WAR ORGANIZATION.....	9
NATIONAL TUG OF WAR ORGANIZATION .....	10
NATIONAL STRUCTURE OF SPORT ORGANIZATION.....	11
TWIF ADDRESSES .....	12
MEMBER ASSOCIATIONS.....	14
TWIF CONSTITUTION.....	16
RULES OF TUG OF WAR INTERNATIONAL FEDERATION .....	23
RULES FOR INTERNATIONAL COMPETITION .....	27
RULES FOR ADVERTISEMENTS NATIONAL TEAMS.....	46
TERMS OF REFERENCE COMMITTEES / COMMISSIONS .....	49
OFFICIALS INTERNATIONAL COMPETITIONS .....	53
TWIF JUDGES PANEL .....	59
TWIF TIMEKEEPER /RECORDERS PANEL.....	61

# **HISTORY OF TUG OF WAR**

## ***Ancient origin***

There is no specific time and place to pinpoint the origin of Tug of War. The contest of pulling on the rope originates from ancient ceremonies and cults, which are found all over the world Eg. Egypt, Burma, India, Borneo, Japan, Korea, Hawaii and South America. The ancient Tug of War was performed in various styles. In Afghanistan, teams used a wooden stake instead of a rope to pull. In Korea, children clasped their arms around each other's waists to form a living Tug of War chain. Team captains must have had a very strong grip linking the teams together with their hands. Tug of War was not only a team sport; in several countries a man to man version of Tug of War existed. The Canadian Eskimos still have a Tug of War contest known as "ar-saaraq". It's a Tug of War contest with the pullers sitting on the ground, using a short rope. The one who pulls his opponent over from his seated position is the winner.

## ***Tug of War as sport contest***

Later, Tug of War became a pure contest of physical strength. In Greece, the cradle of the ancient Olympic Games, Tug of War sport around 500 BC was practised by athletes either as a competitive sport or as an exercise in the physical training for other sports. In Western Europe evidence of Tug of War is found in the year 1000 AC, in the stories of the heroic champions of Scandinavia and Germany, who participated in the so called "kräftige spiele" (power games). The Tug of War sport featured in competitions at the courts of the Chinese Emperors, as well as in Mongolia and Turkey. In the 15th century Tug of War was a popular contest at the tournaments in the French chateaux and in competitions in Great Britain.

## ***Olympic period***

The Tug of War sport featured in the Olympic Games from 1900 to 1920. The medal winners during that period were;

<b>Year</b>	<b>Venue</b>	<b>Gold</b>	<b>Silver</b>	<b>Bronze</b>
1900	Paris	Sweden	USA	France
1904	St. Louis	USA	USA	USA
1908	London	Great Britain	Great Britain	Great Britain
1912	Stockholm	Sweden	Great Britain	
1920	Antwerp	Great Britain	Netherlands	Belgium

In 1920 the IOC took a decision to reduce the number of participants of the Olympic Games and for that reason deleted a number of team sports from the programme, including Tug of War. In 1999 TWIF received provisional IOC recognition, which was confirmed in 2002 for tug of war to again be formally recognized in accordance with rule 29 of the Olympic Charter.

# **HISTORY OF TUG OF WAR**

## ***National Tug of War Associations***

The discontinuation of Tug of War as an Olympic discipline fortunately did not put an end to the Tug of War sport. All over the world Tug of War remained a popular sports activity. Within the Athletic Associations, Tug of War was still an athletic discipline and on sport festivals Tug of War was a popular inter-village competition. Within National Athletic Associations the Tug of War discipline, being a non-Olympic discipline, did not have the first priority. The Tug of War teams therefore felt the need to establish a separate and independent organization for the Tug of War sport. The oldest national association in Tug of War is the Svenska Dragkamp Förbundet, the Swedish Tug of War Association, founded in 1933. The example of Sweden was followed by other countries; in 1958 by the Tug of War Association of Great Britain and one year later, in 1959, by the Netherlands Tug of War Association.

## ***Foundation of TWIF***

After Tug of War was no longer on the programme of the Olympic Games, the opportunity to participate in international competitions had disappeared. With the foundation of National Tug of War Associations, this need for international competition however remained a high priority. The initiative to form an international federation was taken in 1960 by George Hutton of the Great Britain Association. In co-operation with representatives from the Swedish Association, the idea was brought into reality.

## ***TWIF Competitions***

The first international competition of the new federation was staged at the Baltic Games in 1964 (Malmö, Sweden). The Tug of War International Federation, TWIF, participated with four countries; Great Britain, Sweden, Netherlands and Denmark. After the international competition in the Baltic Games, TWIF organised in 1965 its first European Championship in Crystal Palace, London, Great Britain. From that year on, with regular intervals, European Championships were staged until 1975, when countries from outside Europe affiliated to TWIF, resulting in the first World Championship in the Netherlands. Currently TWIF organises World Championships in both outdoor and indoor every two years. Continental Championships are organised in the intervening years.

# HISTORY OF TUG OF WAR

## ***TWIF affiliation to International Federations***

The Tug of War International Federation (TWIF) is a full Member of the General Association of International Sport Federations (GAISF) and the Association of Olympic Recognised International Sports Federations (ARISF). The TWIF is also a founder member of the International World Games Association (IWGA).

## ***World Games***

Tug of War has been on the programme of all World Games events. TWIF currently participates with three weight classes on the programme. World Games medal winners since 1981 are the following.

Year	Venue	Men	Women	Gold	Silver	Bronze
1981	Santa Clara USA	720		Switzerland	Netherlands	England
		640		England	Switzerland	Netherlands
1985	London UK	720		Rep. Ireland	Switzerland	England
		640		Rep. Ireland	England	Switzerland
1989	Karlsruhe Germany	720		England	Switzerland	Rep. Ireland
		640		Switzerland	Rep. Ireland	England
1993	The Hague Netherlands	720		Switzerland	Rep. Ireland	Germany
		640		Switzerland	Rep. Ireland	Spain
1997	Lahti Finland	720		Netherlands	Sweden	Rep. Ireland
		640		Spain	Switzerland	Rep. Ireland
2001	Akita Japan	680		Netherlands	Switzerland	Sweden
		600		England	Scotland	Japan
2005	Duisburg Germany	680		Netherlands	Sweden	Rep. Ireland
		640		Switzerland	Sweden	Germany
2009	Kaohsiung Chinese Taipei	680	520	Chinese Taipei	Japan	Netherlands
		640		Netherlands	Switzerland	Great Britain
2013	Cali Columbia	700	520	Switzerland	Germany	Netherlands
		640		Chinese Taipei	Netherlands	Great Britain
2017	Wroclaw Poland	700	520	Netherlands	Switzerland	Sweden
		640	540	Switzerland	Great Britain	Germany
				Chinese Taipei	Netherlands	South Africa
				China	Netherlands	South Africa
				Switzerland	Switzerland	Great Britain
				Great Britain	Switzerland	Germany

## **HISTORY OF TUG OF WAR**

### ***TWIF Recognised by IOC***

In July 1999 TWIF was provisionally recognized by the International Olympic Committee.

During the 113<sup>th</sup> Session of the International Olympic Committee in Salt Lake City, USA from 4 – 6 February 2002, TWIF has been granted formal recognition by the IOC pursuant to rule 29 of the Olympic Charter.

## ***INTERNATIONAL TUG OF WAR FEDERATION***

---

### ***Management of the Tug of War sport***

The organizational structure of the Tug of War International Federation (TWIF) is not a complex set-up. The central point is the Congress with administration by an executive body, the Executive Committee comprising of 5 members. The main activity of the Executive Committee is focused on the technical aspects of the organization of international competitions and the global development of the sport. Managerial aspects such as budgeting and planning however are becoming more and more important, in particular the promotion and the public relations of the sport, as well as compliance with the anti-doping requirements of the WADA and the IOC.

### ***TWIF Congress***

TWIF is an assembly of national Tug of War Associations. The highest authority in the TWIF therefore is the Annual Congress. TWIF Congress is the meeting of all affiliated members associations of TWIF in good standing. The TWIF Congress elects the TWIF Executive Committee and ratifies the appointment of Commissions and Committees from time to time.

### ***TWIF Executive Committee***

The Executive Committee is the administrative and management body of TWIF. It manages all TWIF affairs and represents TWIF in international organizations it is affiliated to.

### ***TWIF Commissions***

To assist the Executive Committee in the discharge of its work, TWIF has appointed five Commissions and two advisors.

- Technical and Athletes Commission
- Medical / Doping Commission
- PR and Promotion Commission
- TUE (Therapeutic Use Exemption) Commission
- Appeals Commission
- ICT Information Technology Advisor
- Legal Advisor



## ***NATIONAL TUG OF WAR ORGANIZATIONS***

---

### ***Recognition by National Sports organizations***

A national Tug of War Association needs to be recognized by its National Olympic Committee or National Sports Organisation as a requirement for affiliation to TWIF. As a newcomer in the Tug of War sport, the relation between the Tug of War Association and the national sport administrations is very important for the development of a national Tug of War organization. If required TWIF will assist in achieving the required contacts.

### ***Organisation structure***

The management structure in the affiliated member associations of TWIF varies widely. There is however one particular similarity in the structure of the Tug of War Associations being pre-eminently a team sport, so the Tug of War Associations are primarily Assemblies of Clubs and/or Regional structures.

### ***General Meeting of Clubs***

The General Meeting of clubs is the highest authority in a national association. In some countries the association is subdivided in regions or districts, depending on the number of affiliated clubs and the geographic situation. A President or Chairman heads the national Tug of War Association. The Annual General Meeting elects the Executive Committee, including the Chairman or President.

### ***Executive Committee of National Associations***

Management of the daily affairs of the Tug of War sport is done by the respective Executive Committees, when required assisted by Commissions. These Commissions are established by the Executive Committees to deal with specific items such as: Competitions, Judging and Recording, Training courses and Public Relations. Regional Committees, where applicable, are in charge of the daily affairs of the regions or districts.

### ***National Council***

Some Associations have formed a Council with representatives from the Regional Committees, the Commissions and the Executive Committee. Council Meetings take place annually as required and deal mainly with the general policy of the Tug of War sport in the country, while the Executive Committee meetings deal with the day to day affairs of the Tug of War Association.

## ***NATIONAL STRUCTURE OF SPORT ORGANIZATION***

---

### ***National sport structures***

The organization of the sport in the various countries is not identical; mostly three major administrations are involved;

- National Olympic Committee
- National Controlling Sports organization
- Department of Sport/Recreation (Government)

### ***National Olympic Committee (NOC)***

All countries have a National Olympic Committee (NOC). Since TWIF has been granted Olympic Recognition, several National Olympic Committees (NOC's) have recognized the National Tug of War Associations in their respective countries. However, as it is up to the NOC's to recognise a national association and not all NOC's have as yet accepted or acknowledged the national tug of war association. The Association of National Olympic Committees (ANOC) of the IOC has however formally invited the NOC's to recognise the national associations of Olympic Recognised Sport Federations.

### ***National Controlling Sports organization***

In most countries the national sport is managed by a non-government "umbrella" organization. These non-government sports organizations have different names in the various countries, but are generally known as the National Controlling Sports organizations. There is a trend that the national controlling sports organizations are co-operating - or even merging with the NOC's.

### ***Affiliation to national sports organization***

The affiliation to the National Controlling Sport Body is of particular importance for a national Tug of War Association in order to become eligible for financial support from these organizations. However, the significance of affiliation is not limited to the financial assistance only, the know-how of the national sports body is of great value to the management of national Tug of War associations.

### ***Support from Department of Sport (Ministry of Sport)***

In some countries the Ministry of Sport supports the sport either directly or renders financial support via the National Controlling Sports organization. In some countries regional and/or local authorities financially support the sport on regional or club level, especially through the provision of sports facilities and in the assistance to youth sport activities.

## ***TWIF ADDRESSES***

---

### **Administrative Headquarters.**

*mailing address* Tug of War International Federation  
Lytse Dyk 2  
9026 BD Jellum  
The Netherlands

*Telecom* tel 0031623271158  
fax  
e-mail [10cc@hetnet.nl](mailto:10cc@hetnet.nl)  
*Website* [www.tugofwar-twif.org](http://www.tugofwar-twif.org)

### **twif executive committee**

*President* Mr Anton Rabe tel 27 21 870 2900/  
Mobile 27 (0) 83 453 3422  
PO Box 163 Fax 27 21 870 2915  
Paarl 7620 Email [anton@hortgro.co.za/](mailto:anton@hortgro.co.za)  
South Africa [anton@cantino.co.za](mailto:anton@cantino.co.za)

*secretary general* Mrs. Maaike Hornstra tel 0031582519739  
Lytse Dyk 2 Mobile 0031623271158  
9026 BD Jellum E-mail [10cc@hetnet.nl](mailto:10cc@hetnet.nl)  
The Netherlands

*Senior vice pres* Mr. Pete Dyer tel 44 (0) 1934 823 462  
7 Somerville Road Mobile 44 7557508523  
Winscombe E-mail [pete@dyermail.co.uk](mailto:pete@dyermail.co.uk)  
England U.K.

*vice president* Mr. Jost Waser tel  
Eintracht 4 Mobile 0041794315319  
6386 Wolfenschiessen Email [jostwaser@hotmail.com](mailto:jostwaser@hotmail.com)  
Switzerland

*Treasurer* Mr. Dan McCarthy tel 353 (0) 872308258  
Acre Gate Mobile  
Ballyorban E-mail [Twifjudgedan1@gmail.com](mailto:Twifjudgedan1@gmail.com)  
Monkstown, Co Cork  
Republic of Ireland

<i>Honorary Life President</i>	Mr Co Koren <i>(non Executive position)</i> Slot Aldeborglaan 33 6432 JM Hoensbroek Netherlands	tel + 31 563 1089 fax + 31 563 1079 e-mail cokoren@ziggo.nl
<i>Honorary Life President</i>	Mr. Cathal McKeever <i>(non Executive position)</i> 22 Annahugh Road LOUGHGALL Co. Armagh BT61 8PQ Northern Ireland	tel + 44 2838 891 661  e-mail cmckeeper@sky.com
<i>Honorary Life Vice-President</i>	Mr Glen Johnson <i>(non Executive position)</i> PO Box 77 Orfordville WI 53576 USA	Mobile +1 (608) 290-3524  e-mail twif@t6b.com

## **MEMBER ASSOCIATIONS**

---

Please check TWIF website ([www.tugofwar-twif.org](http://www.tugofwar-twif.org)) for up-to-date addresses and tel-com data of national representatives as these change from time-time.

		<b>Member</b>
1	AUS	Australia
2	BAS	Basque Country
3	BEL	Belgium
4	BRA	Brazil
5	BRU	Brunei Darussalam
6	CAB	Cambodia
7	CAM	Cameroon
8	CAN	Canada
9	CHI	Channel Islands
10	CHN	People's Rep. Of China
11	TPE	Chinese Taipei
12	COL	Colombia
13	COG	Democratic Rep of Congo
14	CZE	Czech Republic
15	DNK	Denmark
16	DOM	Dominican Republic
17	ENG	England
18	EST	Estonia
19	FIN	Finland
20	FRA	France
21	GMB	Gambia
22	GEO	Georgia
23	GER	Germany
24	GHA	Ghana
25	GRE	Greece
26	HTI	Haiti
27	HKG	Hong Kong China
28	HUN	Hungary
29	IND	India
30	IRI	Iran
31	IRL	Ireland
32	ISR	Israel
33	ITA	Italy
34	JPN	Japan
35	KEN	Kenya
36	KOR	Korea
37	LAO	Lao-DRP
38	LAT	Latvia

39	LTU	Lithuania
40	MAC	Macau
41	MYS	Malaysia
42	MAL	Malta
43	MRI	Mauritius
44	MGL	Mongolia
45	MOR	Morocco
46	MYA	Myanmar
47	NAM	Namibia
48	NEP	Nepal
49	NED	Netherlands
50	NGR	Nigeria
51	NIR	Northern Ireland
52	PAK	Pakistan
53	PHI	Philippines
54	POL	Poland
55	ROU	Romania
56	RUS	Russia
57	SCO	Scotland
58	SER	Serbia
59	SLE	Sierra Leone
60	SIN	Singapore
61	SVK	Slovakia
62	RSA	South Africa
63	SRI	Sri Lanka
64	SWE	Sweden
65	SUI	Switzerland
66	THA	Thailand
67	TUR	Turkey
68	UKR	Ukraine
69	USA	United States
70	VIE	Vietnam
71	WAL	Wales
72	ZAM	Zambia
73	ZIM	Zimbabwe

## ***TWIF CONSTITUTION***

---

### **ARTICLE 1 - Founding**

The Tug of War International Federation is an Amateur Federation founded in 1960, further referred to as "TWIF". It is affiliated to the General Association of International Sports Federations (GAISF), the Association of Olympic Recognised Associations (ARISF) and the International World Games Association (IWGA) and follows the Olympic Principles in its activities.

### **ARTICLE 2 - Interpretation Clause**

In interpreting the Constitution and Rules of the Tug of War International Federation; the following definitions apply:

- a) "The Associations" refers to the National Associations in control of Tug of War in their respective countries.
- b) "Member" means a National Tug of War Association, which is in membership of "TWIF".
- c) "British Associations" refers to the Associations of the United Kingdom, i.e. the English Tug of War Association, the Scottish Tug of War Association, the Welsh Tug of War Association, the Northern Ireland Tug of War Association and the Tug of War Association of the Channel Islands
- d) "Executive" refers to the Executive Committee of TWIF.

### **ARTICLE 3 - Objects and General Provisions**

The objective and purpose of TWIF is:

- (1) To encourage, promote and control International Competition between Members. To work together to develop world-wide competition in Tug of War, to participate in global multi-sports events such as The World Games and to strive for the re-inclusion of the sport in the Olympic Games.
- (2) To develop and intensify friendship and co-operation between the Association and all their Members.
- (3) To set up Rules for Tug of War to ensure uniformity of control; to hold development and training courses and examinations to set up International Panels of Tug of War Judges and Timekeeper Recorders.
- (4) To regulate and control exclusively on the technical and sporting basis, World Championships, Continental Championships and International Competitions on the programme of major multi-sport event such as the World Games and the Olympic Games.

### **ARTICLE 4 - Headquarters**

The Headquarters of the TWIF shall be determined by Resolution of Congress. For the time being it shall be in Lucerne, Switzerland, and can be transferred to another country by a two-third-majority vote of Congress.

## **ARTICLE 5 - Members**

- (1) The TWIF shall consist of affiliated Members, which are recognized as the only Association controlling Tug of War in their respective Countries.
- (2) The Association in Membership with TWIF shall recognize each other as the ONLY Associations controlling Tug of War in their respective countries, to the exclusions of all others.
- (3) A Member will be regarded as in “good standing” with the status to participate in TWIF events such as championships and congress, only when all its obligations in terms of the appropriate annual membership fee and annual reporting, including anti-doping reporting, have been submitted and acknowledged by the Secretary General and/or Treasurer.

## **ARTICLE 6 - Congress**

Congress, which is the highest power of TWIF, is formed by the affiliated Members. Each Member Association may be represented by two delegates, one being the International Representative of the Member Association.

Congress could be held either physically (in person) or via an appropriate virtual platform.

## **ARTICLE 7 - Congress Power**

TWIF Congress will have the power:

- a) To decide on the affiliation of new Members.
- b) To elect the Executive.
- c) To elect Special Committees and Commissions.
- d) To change the Rules of Competition of TWIF.
- e) To change the Constitution and the Rules of TWIF.
- f) To decide on the Suspension and Expulsion of Members and the Dissolution of TWIF.
- g) To decide on special funds and fees.

## **ARTICLE 8 - Quorum**

The Quorum necessary for holding Congress is one third of the Affiliated Members in good standing. If fewer members attend, only a Meeting of the Members can be held, without the powers of Congress.

## **ARTICLE 9 - Voting - Election**

### **Voting.**

Each Affiliated Member in good standing has one vote only. Unless otherwise specified in this Constitution, voting of Congress and within the Executive Committee must be approved by a simple majority of the valid votes taken. If the result of voting is equal, the Presiding Officer may give the casting vote. Voting by proxy is permitted. If either time or situation do not allow for the organization of an Extra-ordinary Congress, the Executive may hold a voting by letter.

### **Election.**

Elections will be by secret ballot.



## **ARTICLE 10 - Extra-ordinary Congress**

The Executive Committee may, at any time, and must at the written request of two-thirds of the Members, in good standing, of TWIF, call an Extra-ordinary Congress.

## **ARTICLE 11 - The Executive Committee**

- (1) The following officials shall be elected by the Members and appointed to act as the Executive:
  - a) President
  - b) Senior Vice President
  - c) Vice President
  - d) Secretary General
  - e) Treasurer
- (2) The duration of their appointment shall be four years based on a staggered rotational schedule with 2 years overlapping periods. The President, Vice-President and Secretary General will be elected in the same 4-year cycle, whilst the Snr Vice-President and Treasurer will be elected in the same 4-year cycle. After this period the officials can be re-elected by Congress.
- (3) When, during the period mentioned in paragraph 2 of this Article, an official resigns from the Executive or is no longer available to act as an official, the Executive may appoint an official to act in the vacant office for the duration of the period until the next Annual Congress.

## **ARTICLE 12 - Executive Committee Powers**

- (1) The Executive Committee is the Administrative Body of TWIF. It manages the affairs of TWIF according to the Rules and it represents TWIF at all occasions. It has to prepare the Annual Congress and report its activities to Congress. The Executive can appoint interim officials in case of resignation of officials.
- (2) The Executive proposes the assignment of a Legal Advisor and/or Arbitrators, if necessary. The assignment of the legal advisor and arbitrators shall be approved by Congress.
- (3) The Executive can, when needed for a special task or liaison, co-opt up to a maximum of two (2) officials, whose term of office will end on the termination of the special task or liaison.
- (4) The Executive Committee is empowered to suspend or expel Clubs and/or Individuals from participation in international tug of war, when Clubs and/or Individuals are liable of action bringing the tug of war sport into disrepute.
- (5) Appeals against decisions and rulings passed by the Executive Committee shall be lodged within 21 days with the TWIF Appeals Commission.

## **ARTICLE 13 - Committees and Commissions**

The Committees and Commissions necessary shall be proposed by the Executive and ratified by Congress.

## **ARTICLE 14 - Affiliation Fee**

The Affiliation Fee is payable in the first month of the year. A member, who does not pay the affiliation fee for the current year, will not be allowed to take part in TWIF Championships or Congress until the affiliation fee is fully paid.

## **ARTICLE 15 - Fees**

The rules may stipulate the fees necessary for the financial needs of TWIF such as the Permit Fees for International Competitions.

## **ARTICLE 16 - Financial Year**

The Financial Year shall run from 1st November until 31st October. The finance of TWIF shall be vested in the Executive. The Treasurer will submit certified accounts and balance sheet to the Annual Congress.

## **ARTICLE 17 - Auditors report**

The Treasurer will submit the Accounts and Balance Sheet, three months prior to Congress to a firm of Chartered Accountants for their inspection and they in turn, will submit a written report (Auditors report) on their inspection to Congress.

## **ARTICLE 18 - Resignations, Suspensions and Expulsions**

**Resignation:** A Member may resign at any time provided that at the time of resignation the Member has no outstanding liabilities to the Federation and is at the time a fully paid-up Member. Such resignation shall take effect immediately upon receipt by the Secretary General of a Notice of Resignation signed by two Members of the Executive Committee of the Member and shall be reported at the next Annual Congress by the Secretary General.

### **Suspension:**

- (1) The Congress is responsible for suspending members, clubs and/or individuals by a recommendation of the Executive Committee and a 50% +1 majority decision of votes taken of the Annual Congress.
- (2) Decisions taken by Congress supersede any disciplinary actions taken by an individual member association.
- (3) The Executive Committee may, with immediate effect, suspend members, clubs and/or individuals that seriously violate its obligation as a member or through its/their actions bring the sport into disrepute.
- (4) Suspension pronounced by the Executive Committee shall last until the next Annual Congress unless the Executive Committee has lifted it in the meantime. Such suspension shall be confirmed at the next Congress by a 50% + 1 majority of votes taken. If the suspension is not confirmed by the Congress, the suspension is automatically abolished.
- (5) A suspended member, club, and/or individual shall lose its/their membership rights.
- (6) Other members, clubs, or individuals may not entertain sporting contact with suspended members, clubs or individuals.

**Expulsion:** A member may be expelled from Membership of the TWIF on a resolution passed by a 75% majority of the Federation Members present at an Annual Congress or an Extra-ordinary Congress specially convened, for the following reasons:

- a) Refusal to pay any liabilities due to TWIF.
- b) Refusal to comply with the provisions of these Articles.
- c) Persistent action liable to bring the sport of tug of war into disrepute as agreed by the Executive Committee.

## **ARTICLE 19 – Court of Arbitration for Sport (CAS)**

- (1) TWIF recognises the Independent Court of Arbitration for Sport (CAS) with headquarters in Lausanne, Switzerland, to resolve disputes between TWIF, Members, clubs and individuals.
- (2) The provisions of the CAS Code of Sports-Related Arbitration shall apply to the proceedings. CAS shall primarily apply the various regulations of TWIF, and additionally, Swiss Law.
- (3) Appeals against decisions and rulings passed by the TWIF Appeals Committee or Congress shall be lodged with CAS within 21 days of notification of the decision in question.
- (4) Recourse may only be made to CAS after all other internal channels have been exhausted.
- (5) CAS however, does not deal with appeals rising from:
  - (a) violations of the rules of the tug of war sport
  - (b) suspensions for up to 2 Indoor and/or Outdoor TWIF Championships whatever may be applicable to the particular incident or dispute.
- (6) The appeal shall not have a suspensive effect.
- (7) Any costs associated with the appeal to CAS shall be borne by the party lodging the appeal.

## **ARTICLE 20 - Obligation**

- (1) Members and clubs shall agree to recognise CAS as an independent judicial authority and ensure that their members, officials and individuals comply with the decisions passed by CAS.
- (2) Recourse to ordinary courts of law. In matters associated with transgressions against articles and clauses contained in the TWIF Constitution and Rules is prohibited until internal remedies and appeals procedures as listed within the constitution and rules have been exhausted. These remedies include referral to CAS.
- (3) To ensure the foregoing, Members shall insert a clause in their statutes stipulating that their clubs and individuals are prohibited from taking a dispute to ordinary courts of law until all internal remedies referred to in (2) above have been exhausted.

## **ARTICLE 21 – TWIF Appeal Commission**

### **Term of office:**

Shall be 4 years coinciding with the 4-year cycle of the President's term of office.

### **Composition:**

- (a) The Commission will consist of 3 members
- (b) The TWIF Legal Advisor will serve as Chairman of the Commission
- (c) Members in good standing will nominate and Congress will appoint 2 members and 2 alternates to serve on the Commission.

### **Terms of Reference & Procedures:**

- (a) The Commission is responsible for hearing appeals against decisions of the Executive Committee that have not been confirmed by Congress. Any appeal must be lodged within 21 days.
- (b) The Commission may determine the procedures to be followed during the appeal process on a case-by-case basis.
- (c) The Commission shall pass decisions only when at least 3 members (of which the Chairman/Legal Advisor must be one) are present.

- (d) The Commission will announce its ruling/decision via the normal TWIF communications and circulars to all members.
- (e) Any party wishing to appeal to the Appeal Commission shall deposit an amount equal to 3x the annual membership affiliation fees at the time, with the TWIF Treasurer before any appeal process will be initiated.
- (f) If the appeal is lost, the deposit will be retained by TWIF to cover the costs associated with the appeal and the Appeal Commission.
- (g) If the appeal is upheld, the deposit will be returned. TWIF will however not cover any expenses (travel, legal or otherwise) of the Appellant.

## **ARTICLE 22 – Interpretation of Constitution and Rules**

In case of a dispute arising from interpretation of the Constitution or Rules, the TWIF legal advisor, when so requested by the Executive or two Members, has to be consulted before any decision is taken by Congress.

For any dispute in these matters, the English text shall apply.

## **ARTICLE 23 - Modifications**

Modifications of any Articles of this Constitution may only be effected by the Annual Congress or an Extra-ordinary Congress convened especially for that purpose. The majority has to be 75% at any ballot.

## **ARTICLE 24 - Special Provisions - Non-Amateurs and Professionals**

The Tug of War International Federation, as the Controlling body for Tug of War throughout the World may, if Congress approves, and without prejudice to the foregoing Articles, take under its jurisdiction and control non-amateurs and professionals. Non-amateurs and professionals shall be subject to special registration with TWIF which means they will be listed in the Records of Control with TWIF.

## **ARTICLE 25 - Dissolution**

The intended dissolution of TWIF shall require an Extra-ordinary Congress at which sole item on the Agenda shall be the business of dissolution. The quorum for dissolution shall be 75% of the Membership and the vote for dissolution shall require a majority of 75% of the Voting Members present.

If, upon dissolution of the Federation there remains after satisfaction of all its debts and liabilities, any property whatsoever, the same shall not be paid to or distributed among Members of the Federation, but shall be applied to the furtherance of any object or objects as may be determined by the Federation, at or before the dissolution, and, in so far as effect cannot be given the foregoing provisions, then to some charitable object.

## **ARTICLE 26 - Any Other Matters**

Any other matters, which are not covered by the Constitution, Rules and Rules of Competition of TWIF, must be referred to the Executive Committee prior to any discussion being allowed by Congress.

## **ARTICLE 27 - Date of Acceptance and Inception**

These Articles making up this Constitution were approved by the Annual Congress at Engelberg, Switzerland, on 14 May 1983 and came into force immediately.

Amended by the Annual Congress at Drogheda, Rep of Ireland	on 11	April	1992
Amended by the Annual Congress at London, England	on 24	April	1993
Amended by the Annual Congress at Rochester, USA	on 18	April	1998
Amended by the Annual Congress at Cento, Italy	on 21	April	2004
Amended by the Annual Congress at Cape Town, South Africa	on 7	May	2005
Amended by the Annual Congress at Minehead, England	on 6	May	2006
Amended by the Annual Congress at Stenungsund, Sweden	on 12	May	2007
Amended by the Annual Congress at Amsterdam, Netherlands	on 26	April	2008
Amended by the Annual Congress at Pretoria, South Africa	on 2	May	2009
Amended by the Annual Congress at Belfast, Northern Ireland	on 30	April	2016
Amended by the Annual Congress at Cork, Republic of Ireland	on 28	April	2018
Amended by the Annual Congress at Getxo, Basque Country	on 27	April	2019

# ***RULES OF TUG OF WAR INTERNATIONAL FEDERATION***

---

## **ARTICLE 1 - Affiliations**

A National Tug of War Association wishing to affiliate to TWIF must send to the Secretary General the following documents:

- A written request for affiliation signed by TWO Members of its Executive.
- A statement that its Constitution and Rules for Tug of War are in compliance with the TWIF Constitution and Rules.
- A statement certifying that it is the only Controlling Body for Tug of War in its Country, as confirmed by the National Sports Governing body of the country.

## **ARTICLE 2 - Affiliation Fee**

The annual affiliation fee shall be paid in the currency of the Treasurer's choice. The annual affiliation fee for Members shall be determined by Annual Congress.

## **ARTICLE 3 - Congress**

Members shall be represented at Congress by representatives of their own Association who will give proof of their membership being in good standing, and also of their appointment to attend Congress. These members must be of the nationality or citizenship of the country they represent and their credentials must be sent to the Secretary General of TWIF by letter prior to the date of the Congress. Before the opening of Congress the Secretary General of TWIF will verify the credentials of the delegates to the Congress. Any cases of doubt will be referred to the Executive. All sessions of the TWIF Congress are private.

## **ARTICLE 4 - Agenda**

The Agenda for Annual Congress shall include the following items:

- (1) An Address by the President
- (2) The appointment of Scrutineers
- (3) Confirmation of the Minutes of the previous Congress
- (4) Matters Arising
- (5) Report covering the period since the previous Congress
- (6) Submission and vote on the Balance Sheet and Accounts
- (7) Affiliation of New Members
- (8) Proposals and questions submitted by Members and all other matters which the Executive Committee wishes to propose
- (9) If required, the election or re-election of the Members of the Executive
- (10) Reports from Commissions appointed by Congress
- (11) Approval of budget for the next year
- (12) Any other business for the good of TWIF

## **ARTICLE 5 - Standing Orders for Congress of TWIF**

- (1) The date, time and place of Congress must be notified to Members, by letter from the Secretary General, posted at least four months in advance.

- (2) All proposals and questions submitted to Congress by the Member Associations must be sent by letter to reach the Secretary General of TWIF not later than the 1<sup>st</sup> of January of the year of the Congress.
- (3) The Agenda specifying the nature of the business to be discussed by Annual Congress, a copy of the Accounts and Report of the Financial Inspection Committee will be sent to the Associations two months before the date of the Congress.
- (4) No proposal passed or failed can be brought forward to be put on the agenda for two years unless brought forward by the Executive. (Congress April 1987)
- (5) The place, date and time and the Agenda for an Extra-ordinary Congress must be notified at least three weeks before it takes place.
- (6) Only those items included in the Agenda will be discussed by Congress.
- (7) The President of TWIF shall take the chair at Congress.
- (8) The President shall ensure the strict application of the present Standing Orders. He shall open and adjourn the Sessions and Debates, unless the Congress should decide otherwise, give permission to speak and conduct the proceedings. The President will open and close the Congress with an Address to Members of TWIF.
- (9) The President shall maintain order at Congress and may propose to Congress penalties to be inflicted on those Members who interfere with the proper procedure of the discussions, or are guilty of misconduct towards their colleagues.  
The penalties shall be:
  - a) A call to order;
  - b) Censure;
  - c) Exclusion from the Meeting.
- (10) In the case of an appeal, Congress shall decide immediately and without debate.
- (11) The Secretary General will be responsible for the Minutes.
- (12) At the beginning of Congress, Scrutineers will be appointed to count votes for and against, whenever a vote is taken.
- (13) Official Interpreters will be allowed as necessary.
- (14) The Secretary General shall be responsible for recording the debates.
- (15) Each discussion shall be opened by statement:
  - a) By the President, or by the Executive to act for him/her, if the item in question has been placed on the Agenda by the Executive.
  - b) By the representative of the Member responsible for the inclusion of that item on the Agenda.
 The general discussion will then open.
- (16) The right to speak shall be granted in the order in which it is requested. No speaker shall start speaking before he has permission to do so. A speaker cannot obtain permission to speak a second time if a Member who has not yet spoken requests permission. The President will decide the number of speeches allowed to delegates and their duration.
- (17) If a Motion for Adjournment is proposed, discussion on the main question shall be suspended until a vote has been taken on the Motion.
- (18) All amendments to proposals shown on the Agenda shall be drawn up in writing and passed to the President before being put to the debate.
- (19) If proposal is made to close the discussion, it must immediately be put to the vote without debate.
- (20) If motion (as at 19) is approved, permission to speak shall however be granted only to those Members who have requested the right to speak before the vote was taken. As a general rule, the President shall close the discussion unless Congress shall decide otherwise by a simple majority of those voting.

- (21) Decisions of Congress will come into force after publication, which has to be executed within sixty days.

## **ARTICLE 6 - Voting and Elections**

### **Voting -**

Members in good standing are entitled to ONE vote only. The vote shall be by a show of hands (voting cards). No-one shall be compelled to vote. Before each vote the President shall read aloud the text of the proposal and explain to Congress the method of voting. In case of an appeal, Congress shall decide it immediately. Proposals must be put to the vote in the order in which they are submitted. If there are more than two main proposals they shall be put to the vote in succession and no Member of Congress may vote for more than one of the proposals. Amendments to amendments shall be put to the vote before the amendments, and amendments before the main proposal. Proposals which are not contested shall be considered as adopted. The President shall verify the results of the voting and announce them to Congress.

No-one may obtain permission to speak during voting and until the result has been announced by the President.

### **Voting by Proxy -**

The Proxy vote has to be sent to the Secretary General by letter prior to the date of Congress. It has to indicate clearly how the proxy has to vote on the different subjects on the Agenda. It has to be verified by the Executive.

### **Voting by Letter -**

The Executive having decided on voting by letter, mails or e-mails a bulletin with the subjects to be voted on to the Members in good standing indicating the date by which the vote has to be returned. Voting taken by letter must be approved by a simple majority. They have to be ratified at the next Annual or Extra-ordinary Congress. If not approved, they are considered null from then on.

### **Elections -**

All Elections shall be carried out by secret ballot, by means of the ballot papers. The distribution and count of the ballot papers shall be done by the Secretary, assisted by the Scrutineers.

The number of ballot papers issued shall be announced by the President before the count.

If the number of ballot papers returned is equal to or less than that of the ballot papers issued, the vote shall be valid. If the number exceeds that of the ballot papers issued, the vote shall be declared null and void and another vote shall be taken. Blank or cancelled papers may not be included in the count.

Voting by simple majority is sufficient, for the election of Members. The President shall announce the result of each vote to Congress. The ballot papers returned shall be retained until the last count has been verified and then destroyed immediately afterwards. Committees (with the exception of the Executive) and Commissions are considered elected until revoked by Congress.



## **ARTICLE 7 - The Executive**

During their term of office, Members of the Executive will not be eligible to act as delegates for their own Associations. The Executive may, for its belongings, always vote by letter sent to the Headquarters. The Executive may bind TWIF by joint signatures by two of its Members.

## **ARTICLE 8 - Duties of the President**

- a) The President may attend World Championships, Regional and European Championships and other major events for Tug of War, and his/her expenses shall be paid by TWIF when finance permits.
- b) The President or any person acting in his/her place, may represent TWIF at a meeting of the International Olympic Committee, the GAISF, ARISF and the IWGA and report on such meetings at the next Congress.
- c) The President or any other person appointed by him/her shall take a principal part in the opening and closing ceremonies at the World and other Championships and may present the Awards to the winning competitors.

## **ARTICLE 9 - Finance**

- (1) All financial transactions shall require the signature of the Treasurer and one other member of the Executive.
- (2) The Treasurer will maintain an amount equal to £3.000, - or such sum as agreed by Congress in a working Current Account. Funds in excess of this amount will be transferred to a Hard Currency Account.

## **ARTICLE 10 - Budget**

The Treasurer has to submit to Congress a Budget for the coming year which, if approved, has to be executed with a tolerance of 25%. To exceed the tolerance up to 100% the Treasurer has to be backed by a unanimous vote of the Executive.

## **ARTICLE 11 - Television and Broadcasting**

- a) The rights of television and broadcasting, videotaping or filming the World Championships, Regional or European Championships and other major International Contests under the control of TWIF are the property of TWIF.
- b) All fees involved will be decided and negotiated by the President in consultation with Members of the Executive Committee and representatives of the country or organising committee hosting the TWIF event.

# ***RULES FOR INTERNATIONAL COMPETITION***

---

## **DEFINITIONS AND SPECIFICATIONS**

### **1 TUG OF WAR SPORT**

Tug of War is a sport practised by teams who are bona-fide members of the National Tug of War Associations affiliated to TWIF. The participants must be amateurs, as approved by TWIF, and they will adhere to the Rules and Directions as laid down by the Tug of War International Federation.

### **2 CATEGORIES**

- (a) In International Tug of War competitions, the following categories are recognized:  
Outdoor and Indoor  
Men and Women  
Senior, Under 23 and Junior  
Mixed 4x4 Male & Female
- (b) TWIF organises each year a World Championships for Junior and U23 categories women and men

### **3 WEIGHT CLASSES**

In all International competitions the following team weights will apply:

World (W) European (E) Indoor (I) Outdoor (O)

Ultra Featherweight	not exceeding	480 Kilos Junior Women (I.O.) W
Featherweight	not exceeding	500 Kilos U23 Women (I.O.) W
Light weight	not exceeding	500 Kilos Senior Women (I.O.) W
Light Heavyweight	not exceeding	520 Kilos Senior women (O.) E
Heavyweight	not exceeding	540 Kilos Senior Women (I.O.) W
Heavyweight	not exceeding	560 Kilos Senior Women (O.) E
Lightweight	not exceeding	560 Kilos Junior Men (I.O.) W
Lightweight	not exceeding	560 Kilos Senior men (I.O) W.E
Light Middleweight	not exceeding	600 Kilos U23 Men (I.O) W
Light Middleweight	not exceeding	600 Kilos Senior Men (I) W
Middleweight	not exceeding	640 Kilos Senior Men (I.O) W. E
Cruiserweight	not exceeding	680 Kilos Senior Men (I.O) W. E
Heavyweight	not exceeding	*700 Kilos Senior Men (O) W.E
Catch weight	no weight limitations	
Mixed (4 x 4)	not exceeding	580 Kilos Senior Mixed (I.O.) W. E
Mixed (4 x 4)	not exceeding	520 Kilos Junior Mixed (I.O.) W
Mixed (4 x 4)	not exceeding	560 Kilos U/23 Mixed (I.O.) W

(Note: Weight classes can only be amended on a 4-year cycle)

(Note: 720 Kilos remain on Outdoor programme up to and including 2022)

## 4 WEIGHING AND STAMPING

1. All athletes first collect accreditation, having prepaid.
2. All potential pullers must weigh at a pre-determined time schedule.
3. An accreditation download will be carried out listing all athletes from a particular country. Accessible only by the controller and the appointed representative of a particular country.
4. The athlete will weigh on an individual scale. The number of scales to be determined by the organizers and TWIF. Only one weigh-in on the official scales.
5. After weighing the athletes, the weight will be recorded in an excel spreadsheet, and also hand written on the downloaded excel file as a backup.
6. The athlete will be given his or her certified weight. The athlete can then give his or her weight to the coach of the team.
7. Open Clubs entries.  
The coach of a particular club entering in the TWIF club's competition will bring a completed weigh list to control at a predetermined time. The weigh list shall contain the name, accreditation number and the weight of each puller, totalling the adequate weight of a particular weight class. Eight pullers, coach and trainer only.
  - 7.1 **A coach may change any and all pullers prior to and up until stamping, as long as the maximum weight for that particular weight class is not exceeded. Changes must be reported to control by the coach 30 minutes before stamping begins.**
8. National team weigh in.  
The coach of a national team may choose any pullers that are listed and weighed from the downloaded excel file from his/her country.
  - 8.2 **A coach may change any and all pullers prior to and up until stamping, as long as the maximum weight for that particular weight class is not exceeded. Changes must be reported to control by the coach 30 minutes before stamping begins.**
9. The coach of a particular national team will present a completed weigh certificate to control at a predetermined time schedule.
10. Control shall enter teams in a draw for a particular weigh class, after checking the weight & accreditation numbers against the completed excel downloaded list.
11. Scanners/Bar code readers at designated areas to control substitutions, and team weight checks throughout the competitions.

## 5 AGE LIMITS

### 5.1 Junior category

A puller is eligible to participate in the junior category from the beginning of the year in which the puller reaches the age of 14 years until the end of the year in which the puller reaches the age of 18 years.

### 5.2 Under 23

Male and female pullers are eligible to participate in the Under 23 category from the beginning of the year in which the puller reaches the age of 16 years until the end of the year in which the puller reaches the age of 22 years.

### 5.3 Senior

Male and Female pullers are eligible to participate in the senior category from the beginning of the year in which the puller reaches the age of 16 years.

## **6 Teams and Substitutions.**

### **6.1 Number of pullers in a team**

Teams shall consist of eight pulling members at the start of the competition. The contest will have deemed to have commenced when both teams are in a position to pull under the direct supervision of the judge.

### **6.2 Members national team**

Members of a national team must be citizens of the country the team is representing. Proof of citizenship is only accepted by passport or by a national government issued identification card. Members of the team includes pullers, coach and team attendant.

### **6.3 Conditions for using a substitute**

The substitute may replace any one puller for the duration of the competition. After the substitution has taken place, no other such changes may occur.

Substitution may be used for tactical reasons or due to injury.

Substitution may only take place after the team has weighed-in, and has finished the first end of the first match it pulls in.

The replaced puller shall not participate in any subsequent matches of that weight-class.

The substitute must be a registered puller of the specific Club or Country for which he/she acts as a substitute.

### **6.4 Substitution procedures.**

Both, the puller to be replaced and the substitute, must report in full pulling outfit, (shirts, shorts, stockings and footwear) with both of their accreditation cards available for checking by the Official in charge of the match; before being sent to the Official designated by the Chief Judge to deal with the substitutions.

6.4.1 Accreditation cards will be used to verify the athletes and their weights, by scanning or typing the accreditation cards into the system.

The substitute puller must be of equal weight or less than the puller he/she replaces. The total weight of the team cannot be increased by the weight of the substitute, even if the team originally weighed less than the maximum weight for that weight class.

Directly after the change, the Chief Judge or designated official shall cancel the stamp or marking of the replaced puller, and indicate a similar marking on the substitute, with an indelible marker. The Chief Judge or the designated official shall note the substitution on the appropriate weight certificate, by adding and deleting the accreditation numbers of the pullers involved with the changes.

### **6.5 Minimum number of pullers.**

A second substitution will not be permitted. Should a second injury occur, the team is allowed to continue with seven pullers. A team is not allowed to continue a competition with less than seven pullers.

## **7 COACH / TRAINER**

Each team may have a team coach to direct their pulling.

One trainer for each team is also allowed. The trainer's function is to take care of his team before and after pulls. He is not allowed to communicate to his/her team whilst

they are pulling and must take up position as directed by the judge in charge of the match.

## 8 SPORT EQUIPMENT

### Sport dress

#### 8.1.1 *Sport dress puller*

Teams will wear proper sports clothing consisting of shorts, sports shirt or jerseys and knee-stockings or socks. The sport dress of the pullers in the teams shall be uniform.

#### 8.1.2 *Sport dress coach and team attendant*

Coach and team attendant of a team will wear either the same proper sports dress as the team or will wear proper tracksuit which shall conform to the colour(s) of the sport dress of the teams

#### 8.1.3 *Headgear*

Pullers, coach and team attendant are allowed to wear the following headgear; cap, visor or bandanna. The headgear shall conform to the colour(s) of the sport dress.

*Exemption: Headgear such as turbans or other such headgear may be allowed according to religion or culture. This would be decided on a case by case basis by the Chief Judge.*

#### 8.1.4 *Protective clothing*

Clothing to protect the skin may be worn under the sport clothing subject to judge's approval. A leather or woven belt may be worn by a puller to support his/her back during competition. No construction or additional material may be attached to any belt. The buckle or closing apparatus of the leather belt cannot come into contact with the rope and must be worn to the front of the body. The loose ends of a woven belt cannot come into contact or be wrapped around the rope and must be worn to the front or opposite side of the rope. Under no circumstances will the rope be permitted to run BETWEEN the belt and the pullers' body.

Any belt should be made available for inspection by a judge at any time during a tournament.

The protective clothing worn by the anchor shall not exceed a maximum thickness of 5 centimetres; it must always be worn under the sport clothing and placed between the rope and the body. No hooks, grooves or other constructions intended to lock the rope are allowed on any of the protective clothing. Recommended Anchor vest (see page 45)

## 8.2 Resin

Resin is allowed to facilitate the grip on the rope and the use is restricted to the hands only. In **indoor** competition resin may only be used when authorisation is obtained to

utilise resin in the sports hall; if permitted to use resin in the sports hall it shall be applied under the directions of the judges only.

### **8.3 Dress at weigh-in**

Men-teams may weigh-in in proper sized non-transparent shorts only.

Women-teams may weigh in proper sized non-transparent shorts and shirt or suitable sports top.

Boots need not be carried or worn on the scale during weigh-in, but should be presented for inspection by officials during the weigh-in to ensure compliance with boot specifications.

### **8.4 Shoes**

#### **8.4.1 Outdoor shoes**

Heel: The heel shall be flush with the sole of the shoe – vertically down from the sole as seen from the back and side of the shoe. The front of the heel facing forward shall also be straight across, perpendicular to the sole and vertically down from the sole of the shoe.

The side of the heel impacting with the ground – the “cutting edge” – can have a tapered edge towards the front of the heel with a maximum protrusion of 15mm to the outside of the heel as measured from the vertical line from the sole. The other side of the heel must be completely flush with the sole and may not have any protruding feature. The breadth of the heel must not exceed the breadth of the shoe.

The maximum height of the heel, including a metal plate with a maximum thickness of 6,5mm, may not be more than 35mm from the bottom of the shoe. The 35mm includes the thickness of the sole. The length of the heel may not be less than one quarter or more than one third of the length of the shoe. (see illustration/drawing Page 42)

#### Sole structure

The sole ‘structure’ (which includes the structure of the heel) may be metal but the sole plate must not be metallic, the minimum thickness of the non-metallic plate is 6.5 mm. (see illustration/drawing)

Front part of the Shoe: Can be built up or left as is. If not built up, the sole can be higher than the heel when viewed on a flat horizontal surface. In this configuration, the sole must be a minimum of 6.5 mm higher than the heel. If built up, the front part of the shoe may not be less than half the total length of the shoe. The maximum height, including the sole may not be more than 35mm. The ‘sole plate’ must not be metallic and be a minimum of 6.5 mm. (see illustration/drawing)

#### 8.4.2. *Indoor shoes*

The shoes to be used for indoor tug of war should be as originally produced by any sport shoe manufacturer. The sole may be adapted but, should not be wider or longer than the upper part of the shoe. The sole should be made of rubber or such material as to give optimum grip but not cause damage to the pulling surface or floor. The maximum length and width of the sole must not exceed the 'bare foot' measurement of the puller by more than 20%. The only material or substance which may be applied to the sole of the shoe is a clean dry cloth which must be devoid of any chemicals or fluids.

Championship controlling Officials shall arbitrate in matters of dispute.

### 9 **ROPE SPECIFICATIONS**

#### 9.1 **Rope dimensions**

The rope must not be less than 10 centimetres (100 mm) or more than 12.5 centimetres (125 mm) in circumference and must be free from knots or other holdings for the hands. The ends of the rope shall have a whipping finish. The minimum length of the rope must not be less than 33.5 metres.

#### **Rope marking**

The tapes or markings shall be affixed so that they are easily adjustable by the judge in the event of the rope stretching or shrinking.

##### 9.1.1 *Rope marking* **OUTDOOR**

Five tapes or rope markings shall be affixed as follows:

- a) one (1) tape or marking at the centre of the rope
- b) two (2) tapes or markings each four (4) metres on either side of the centre marking.
- c) two (2) tapes or markings each five (5) metres on either side of the centre marking.
- d) markings listed in (a), (b) and (c) shall be in three different colours.

##### 9.1.2 *Rope marking* **INDOOR**

Three tapes or rope markings shall be affixed as follows:

- a) one (1) tape or marking at the centre of the rope
- b) two (2) tapes or markings each two and a half (2.5) metres on either side of the centre marking
- c) markings listed in (a) and (b) shall be in two different colours

### 10 **PULLING AREA AND MARKINGS**

#### **Outdoor pulling area and marking**

The pulling area shall be flat, level grass covered surface. One centre line shall be marked on the ground.

## Indoor pulling area and marking

The pulling surface shall be made of a material that will give sufficient friction to normal indoor sports shoes and is approved by TWIF.

The recommended length of the pulling surface will be 36 metres. The recommended width of the pulling surface will be 100 - 120 centimetres

One centre line and two side lines four (4) metres on either side of the centre line shall be marked on the pulling surface/floor.

## PULLING TECHNIQUES RULES

### 11 ROPE GRIP

No competitor shall grip the rope within the length bounded by the outer tapes or markings. At the commencement of each pull the first pulling member shall grip the rope as close as possible to the outer tape or marking.

No knots or loops shall be made in the rope, nor shall it be locked across any part of the body of any member of the team. Crossing the rope over itself constitutes a loop. At the start of a pull, the rope shall be taut with the centre rope marking over the centre line marking on the ground.

### 12 PULLING POSITION

With the exception of the Anchor, every pulling member shall hold the rope with both bare hands by the ordinary grip, i.e. the palms of both hands facing up, and the rope shall pass between the body and the upper part of the arm. For hold of Anchor see Rule 13.

Any other hold, which prevents the free movement of the rope, is a Lock and is an infringement of the Rules. The feet must be extended forward of the knees and team members should be in a pulling position at all times.

### 13 ANCHOR'S POSITION

The end puller shall be called the Anchor. The rope shall pass alongside the body, diagonally across the back and over the opposite shoulder from rear to front. The remaining rope shall pass under the armpit in a backward and outward direction and the slack shall run free. The Anchor shall then grip the standing part of the rope by the ordinary grip; i.e. the palms of both hands facing up, with both arms extended forward. **The Anchor is allowed to keep the rope below the level of the protective clothing and contact with the belt for safety considerations will not constitute a Lock.**

## INFRINGEMENTS OF THE RULES

### 14 INFRINGEMENTS DURING COMPETITION

#### Infringements General

- |   |         |   |
|---|---------|---|
| 1 | Sitting | deliberately sitting on the ground, or failure to return immediately to the pulling position after slipping |
| 2 | Leaning | touching the ground with any part of the body other than the feet   |
| 3 | Locking | any hold which prevents the free movement of the rope   |
| 4 | Grip    | any grip other than the ordinary grip as described in Rule 11, 12 and 13                                    |



- |    |                   |   |
|----|-------------------|---|
| 5  | Propping          | holding the rope in a position where it does not pass between the body and the upper part of the arm  |
| 6  | Position          | sitting on a foot or a limb or the feet not extended forward of the knee  |
| 7  | Climbing the rope | passing the rope through the hands  |
| 8  | Rowing            | repeatedly sitting on the ground whilst the feet are moved backwards  |
| 9  | Anchor Position   | any other than the position described in Rule 13  |
| 10 | Trainer           | trainer communicating to his team whilst they are pulling   |
| 11 | Side-Stepping     | Stepping outside the pulling track, lane or surface. For outdoor this would mean a team moving sideways out of the existing tracks/footholds such that neither foot is in the existing tracks/footholds |

### **Infringements during outdoor competitions**

- |    |           |   |
|----|-----------|---|
| 12 | Footholds | Digging with the heel and making indents in the ground in any way prior to the Judge issuing the instruction to “Take the Strain” |
|----|-----------|---|

### **Interpretation of Inactivity (not leading to disqualification)**

- |    |            |   |
|----|------------|---|
| 13 | Inactivity | teams failing to actively engage in a competitive effort during a pull, leading to a prolonged stalemate, which could bring the sport into disrepute, constitute a “No pull”, (see rule 21) which can be called at any time. The judge will make the coach aware of his/her plan to give a no pull by pointing at his/her watch and if no activity starts, a no pull will follow. <i>The pull will be restarted, and will continue for this match, on either new or less broken ground in the immediate proximity of the original pulling lane. This match <u>will not</u> be allowed to return to the original pulling lane. If a pull with periods of inactivity lasts longer than ten minutes, the Chief Judge will draw the attention of the Centre Judge to call a “No pull” for this purpose.</i> |
|----|------------|---|

### **15 DISQUALIFICATION**

Teams will receive two (2) cautions for infringements of the Rules in any one (1) pull, before being disqualified. For all infringements of the Rules, a team may be deemed guilty if only one person offends.

### **16 BREACH OF THE RULES**

Failure to comply with any of the Rules for International Competition may disqualify teams from competing.

## **COMPETITION MATCHES AND SCORES**

### **17 MATCHES, PULLS AND REST PERIOD**

A point's competition consists of  $(n \times (n-1) \div 2)$  matches, in which  $n$  is the number of teams in the competition. Each match consists of two (2) pulls. A reasonable rest will be granted between pulls.

A maximum of six (6) minutes may be claimed between matches, beginning when a team leaves the arena and ending when a team is in the marshalling area ready to re-enter the arena.

## **18 TOSS**

Before pulling commences the choice of ends will be decided by the toss of a coin. After the first pull, the teams will change ends. If a third pull is necessary, the choice of ends will again be decided by the toss of a coin.

## **19 WINNING A PULL**

### **19.1 Winning a pull general**

A pull is won by a team either by moving the rope the required distance as indicated by the markings or through the disqualification of the other team by the judge.

### **19.2 Winning pull outdoor**

A pull is won when one of the side markers on the rope is pulled beyond the centre line marking on the ground.

### **19.3 Winning pull indoor**

A pull is won when the middle marker on the rope is pulled beyond the side marking on the floor.

## **20 SCORE**

### **20.1 Point's Competition**

A team winning a match by two (2) pulls to nil will score three (3) points, the losing team will score no (0) points. Teams winning one pull each; each team will score one (1) point.

### **20.2 Pull-offs, Semi Finals and Finals**

Matches will be won by two (2) pulls out of three (3). A team winning a match by two (2) pulls to nil (0) will score three (3) points, the losing team scoring no (0) points. A team winning a match by two (2) pulls to one (1) will score two (2) points, the losing team scoring one (1) point

## **21 NO PULL**

A "No Pull" will be declared in the event of;

- a) both teams being guilty of infringements; after twice being cautioned
- b) both teams being guilty of inactivity: A warning (judge pointing to his/her watch) shall be given to both teams before a No Pull for inactivity is given in order for both teams to have a possibility to react. Any cautions will be carried over to the new pull.
- c) both teams leaving go of the rope before the finish of a pull
- d) a pull being interrupted without infringement by either of the teams, the teams will be granted a reasonable rest and retake the pull.

- 21.1** When a “No pull” is declared, in the case a), during the points phase of a competition, in the event of a “no pull”, the pull will not be repeated. Both teams get nil (0) points and three (3) cautions for that end. If one of the teams win the other end, that team will get 1 point and the other team nil. If both ends during a match results in a “no pull”, both teams will get nil (0) points and six (6) cautions.

This change will not be applicable to rule 20.2, for pull-offs, semi-finals and finals.

## **JUDGING**

### **22 OFFICIALS AND JUDGES**

Officials shall be appointed by the Tug of War International Federation to have control of all international competitions.

The final selection of judges for international competition shall be the responsibility of the Technical Commission.

### **23 POWERS OF REFEREE, CONTROLLER AND CHIEF JUDGE**

In case Clubs and/or Individuals at an event are liable of action of bringing the tug of war sport into disrepute, the Referee, Controller and the Chief Judge, in coordination with each other, are empowered to expel the club and/or individuals from further participation during the event. The Referee shall prepare a report to the TWIF ExCo, which in accordance with Article 12 of the Constitution might take further disciplinary action against the club and/or individuals

### **24 POWERS AND RESPONSIBILITIES OF THE JUDGE**

The appointed judge for a match shall have sole control.

He shall be responsible for ensuring:

- (1) that the Rules of “TWIF” are adhered to
- (2) that the rope is laid out ready for competition before the teams arrive in the pulling area
- (3) that, as far as possible, the pre-determined timetable is adhered to.
- (4) grant rest periods as shown in Rule 17
- (5) declare a “No pull”
- (6) disqualify a team or teams after caution.
- (7) a judge may award only 1 friendly caution to a particular team during a pull.
- (8) disqualify a team without caution which he deems to be guilty of ungentlemanly conduct, by word or act, which is likely to bring the sport into disrepute.

In the event of the judge in charge giving a caution, which he will indicate by the common signal code, naming the team and adding “first caution” or “last caution”. Any such instructions given by the judge in charge must be clear and brief using the appropriate signals.

The judge’s decision shall be final at all times.

### **25 RESPONSIBILITIES OF SIDE JUDGES**

Side judges shall at all times act under the directions of the judge in charge. During the actual pulling the side judge shall take up a position alongside the competing teams

and to the opposite side of the judge in charge. The side judge shall observe the competing teams and indicate the infringements of the teams to the judge in charge, using the common signal code. The side judge will inform the offenders of the cautions given by the judge in charge.

## 26 WEIGHMASTER

In international competitions, stewards may be appointed by TWIF who shall be responsible to the Weigh master (judge in charge of the weigh-in) for correctly weighing and stamping all competitors.

## SIGNALS AND COMMANDS

### 27 THE START PROCEDURE

When the judge has received a signal from the two coaches that all is ready, he shall give the teams the following verbal and visual commands:

Pick up the rope	The rope shall then be gripped as defined in paragraphs 11, 12 and 13, the feet being flat on the ground
Take the Strain	Sufficient strain being put on the rope to ensure that it is taut. In out-door competitions each puller may establish one foothold with the heel or side of the boot with the extended foot
Steady	The judge shall then signal the rope to the centre position. When the rope is steady with the centre mark over the centre line on the ground
Pull	After a reasonable pause

### 28 FINISH OF A PULL

The finish of a pull shall be signalled by the judge blowing a whistle and pointing in the direction of the team winning the pull or in the case of a "No pull" crossing his arms and pointing to the centre mark.

### 29 LIST OF COMMANDS IN TUG OF WAR COMPETITION

COMMAND	SIGNAL
1 Team are you ready	Indicating the team with the arm
2 Pick up the rope	Arms extended in front of the body
3 Take the strain	Arms extended upwards with hand palms inward
4 Rope to centre	Indicating the side which has to move to centre
5 Steady	Arms extended upwards with palms outwards
6 Pull	Flinging arms down to the sides
7 Indicate winner	Blowing whistle and pointing to the winning team
8 Change ends	Blowing whistle and crossing the arms over the head
9 No Pull	Blowing whistle and crossing the arms in front of the body
10 Caution	Raising the arm on the side of the infringing team and indicating by one or two fingers the first or second caution
11 Inactivity	Pointing to wristwatch before a no pull for inactivity is given

### 30 LIST OF COMMON INFRINGEMENTS IN COMPETITION

INFRINGEMENTS	SIGNAL
---------------	--------

1 SITTING	moving flat hand horizontally
2 LEANING	open hand horizontal indicating to the ground
3 LOCKING	elbow touching the lifted upper leg
4 GRIP	two fists in front of each other
5 PROPPING	lifting movement with hands along the body
6 POSITION	kicking movement and stretching of the lower leg
7 CLIMBING THE ROPE	climbing movements with the fists
8 ROWING	rowing motion with arm and upper body
9 ANCHOR'S GRIP	with the hand touching the back
10 TRAINER	with the finger touching the lips
11 SIDE-STEPPING	side stepping with one foot
12 FOOTHOLDS	kicking with heels in the ground
13 INACTIVITY	pointing to wristwatch

## COMPETITION STRUCTURE

### 31 General

The TWIF International Championships competition consists of a qualifying round, semi-finals and finals.

- The qualifying round will be a point's competition. The draw shall be made in the presence of the appointed delegates to the Tug of War International Federation. (See rule 37)
- The qualifying competition will result in four teams entering the semi-finals. The losers of the semi-final matches enter into the pull-off for the bronze medal and the winners of the semi-final matches enter into the final for the silver and the gold medals.

### 32 Minimum number of teams

A minimum number of 4 teams per weight class are required for participation in World or Continental Championships. If there are not four teams taking part in a particular weight class, it will not be considered a World or Regional Championships

### 33 Competition with one group

When less than 12 teams have entered in a weight class, all teams will compete in one qualifying points competition.

- The top four teams of the qualifying point's competition will enter into the semi-finals.
- The team in 1<sup>st</sup>. place will be matched against the team in 4<sup>th</sup> place and the team in 2<sup>nd</sup> place will be matched against the team in 3<sup>rd</sup> place
- The winners of the matches will then compete for the gold and silver medal and the losers will compete for the bronze medal

### 34 Competition with more than one group

When 12 or more teams have entered in a weight class, the qualifying point's competition will be divided into two groups.

The placing into the groups will be based on the ranking in the previous applicable competitions (regional or world championships)

The teams ranking first and second place after the qualifying point's competition will enter into the semi-finals. The teams ranking first in their group will compete against the

teams ranking second from the other group. In case, after the qualifying competition, the first two teams in a particular group are equal on points, teams will be ranked in accordance with rule 35.

### **Policy to standardize the number of teams in a group**

less than	4 teams	No competition
4-11	teams	1 group
12-22	teams	2 groups
23-44	teams	4 groups
44<	teams	8 groups

**Policy for timing of competitions:** Where there is more than one group at a competition weight class, if those groups have different numbers of teams, that the group(s) with the greater number of teams start a suitable number of pulls before the groups with the lesser number of pulls.

### **35 Determination of ranking in qualifying competition**

In the event that, after the qualifying competition, teams are in contention to enter into the semi-finals the following rules will apply to determine which team(s) will qualify for the semi-finals. These rules will also apply to rank teams with equal points in qualifying competition

- (1) **Result of matches**  
The team(s) with the best results in the matches between the teams concerned during the qualifying rounds will be first to qualify for participation in the semi-finals.
- (2) **Matches won**  
In the case that the results between the teams do not break the tie the team with the most matches won will go to the semi-finals.
- (3) **Cautions**  
In case the first 2 options do not break the tie, the team(s) with the least cautions in the qualifying rounds will be first to qualify for participation in the semi-finals. (The number of cautions of a team in a match is the total number of cautions accumulated in the pulls of that match. A team being disqualified in the qualifying rounds will be considered to have accumulated 3 cautions during that pull. In the event of a No-Pull, the cautions given prior to declaring a No-Pull will be accumulated to the total number of cautions of the team in that match. In the case of a No-Pull being declared due to infringements as indicated in rule 21 (a.) both teams will accumulate 3 cautions.)
- (4) **Team weight**  
In case the first 3 options do not break the tie, the lightest team(s) will be first to qualify for participation in the semi-final. For this criterion the certified weight on the weighing sheet will be used.
- (5) **Toss or draw**  
In case all of the above criteria have not broken the tie, the qualification for participation in the semi-finals will be decided by a coin toss or a draw.

### **36 Supervision pull-off and draw**

Following the first draw a second draw may take place, if a team withdraws after the original draw has taken place and the competition for the specific weight class has not started.

- 37** The qualifying round will be a points competition. Should a team or teams (club or national) withdraw from a competition after the draw was made which causes a gross inequality in the number of the teams in different groups, a new draw may be made to ensure a more equal distribution of teams between groups for the point competition. The draw shall be made in the presence of the appointed delegates of TWIF.
- 38** All pull-offs and drawing of lots shall be done under direct supervision of the appointed officials of the competition, these officials shall arbitrate in matters of dispute.

Amendments to Rules for International Competition  
Amended by the Annual Congress at

Drogheda	Rep of Ireland	on	11	April	1992
London,	England	On	24	April	1993
Rochester	USA	On	18	April	1998
Mogelsberg	Switzerland	on	6	May	2000
Pretoria	South Africa	on	28	April	2001
Assen	Netherlands	On	27	April	2002
Rochester	USA	on	3	May	2003
Cento	Italy	On	21	April	2004
Capetown	South Africa	On	7	May	2005
Minehead	England	on	6	May	2006
London	England	on	2	May	2010
Appenzell	Switzerland	on	7	May	2011
Belfast	N. Ireland	on	12	April	2014
Cape Town	South Africa	on	24	Mar	2017
Cork	Ireland	on	28	April	2018
Getxo	Basque Country	on	27	April	2019



**TYPE A**

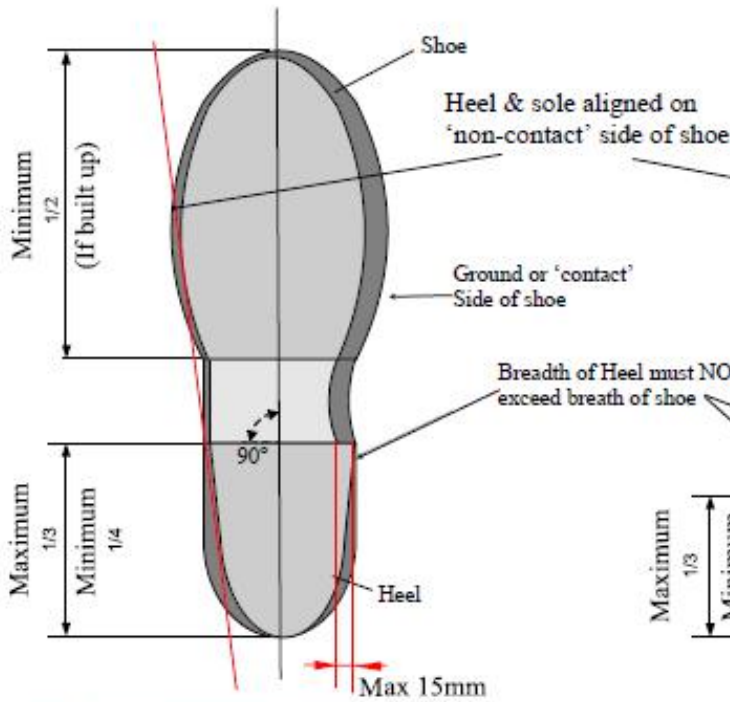

View of bottom of the shoe with 'cut-out' instep

**TYPE B**

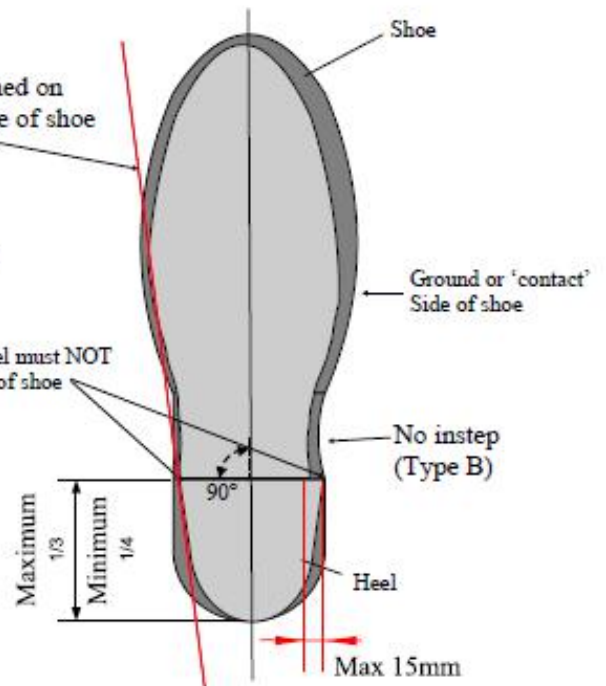

View of bottom of the shoe without 'cut-out' instep

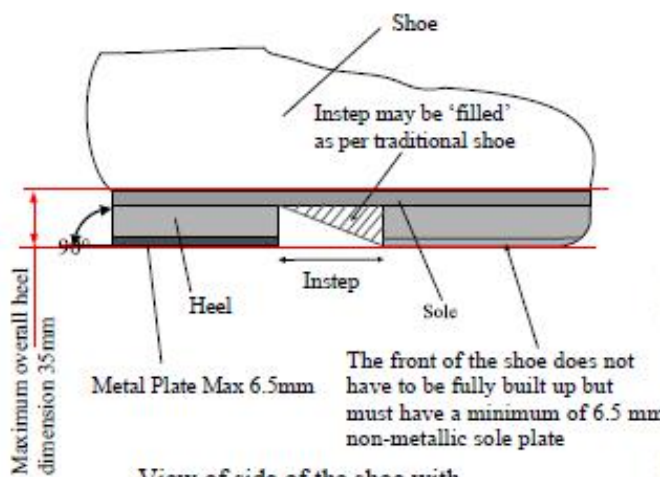

View of side of the shoe with 'cut-out' instep (Type A)

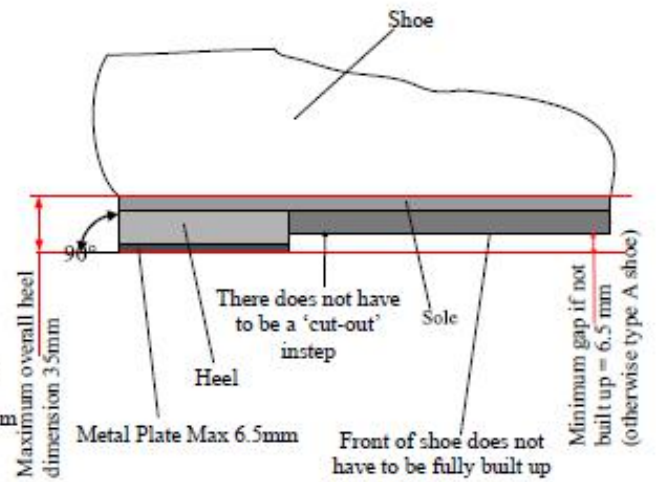

View of side of the shoe without 'cut-out' instep (Type B)

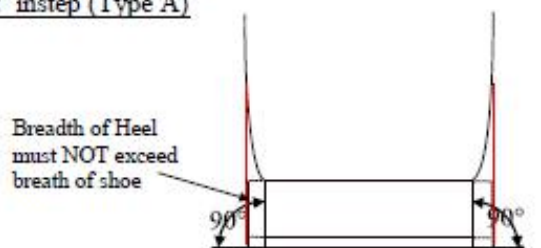

View of heel from the rear of the shoe (Type A and B)

## Attachment 1 Signals Commands

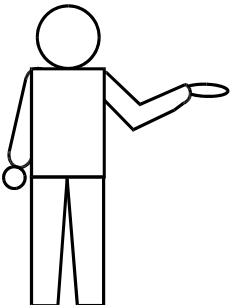
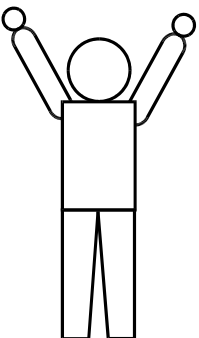
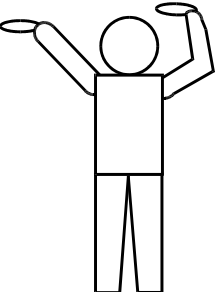
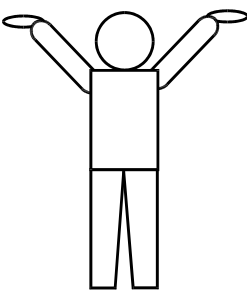
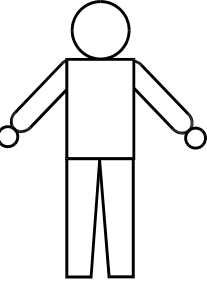
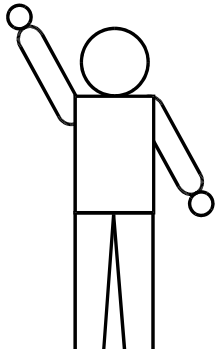
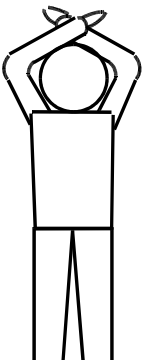
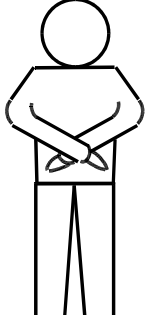
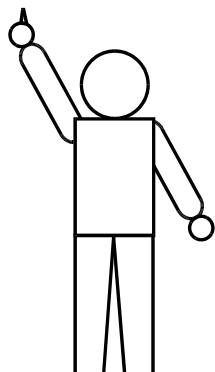
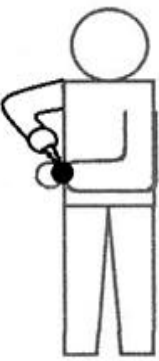
		
TEAM ARE YOU READY	PICK UP THE ROPE	TAKE THE STRAIN
		
ROPE TO CENTRE	STEADY	PULL
		
INDICATING WINNER	CHANGE ENDS	NO PULL
		
FIRST CAUTION	SECOND CAUTION	INACTIVITY

## Attachment 2 Signals infringements

		
SITTING	LEANING	LOCKING
		
GRIP	PROPPING	POSITION
		
CLIMBING	ROWING	ANCHORMAN
		
TRAINER	FOOTHOLDS	SIDESTEP

Ref: 8.1.4: Anchor vest



## ***RULES FOR ADVERTISEMENTS NATIONAL TEAMS***

---

### **1 Conditions for advertisement**

A national team may wear advertisements on the competition dress during TWIF Championships under the conditions as mentioned in these rules. A team consists of 8 pullers, its coach and its trainer.

- The use of company and product names is allowed as well as brand names and product groups as long as they do not offend good taste.
- Advertising must not be of a political, religious or ideological nature.
- Product advertising for alcohol, tobacco and drugs is not allowed.
- The use of fluorescent paints is not permitted. This rule applies not only to advertising but also to the material from which the competition dress is made.
- The competition dress has to comply with the rules of the TWIF.
- Advertising on other articles belonging to the competition dress (e.g. shoes, socks, etc.) is not permitted.

### **2 Dimensions of advertisement areas (See Attachment 3 Pictorial example advertisement)**

The maximum dimensions of- and total areas for advertisements on competition dress of a puller is either;

- a letter height of 10 cm when used in the advertisers name or;
- an area of 300 cm<sup>2</sup>, when used as one advertisement area or;
- a total area of 150 cm<sup>2</sup>, when used on maximum three advertisement areas of which two may be of the same advertiser.

The maximum dimensions of- and total areas for advertisements on competition dress of a coach is;

- a total area of 75 cm<sup>2</sup>, on the dress of a coach, who is wearing an identification number with an advertisement area of maximum 75 cm<sup>2</sup> ( See pictorial examples)

### **3 Identification numbers**

The organiser of the Championship is allowed to use the identification numbers at TWIF events for advertisements. These numbers have to be worn by the coach of the team. The advertisement on the numbers is only permitted for one company or brand name and may not exceed the height of 5 cm and a maximum area of 75 cm<sup>2</sup>. The numbers may not be cut, folded or altered.

### **4 Non liability**

The TWIF is neither responsible nor liable for any disputes which should arise from advertising contracts between a TWIF member federation and the advertising companies or sponsors.

### **5 Penalty on non-compliance**

Non-compliance with these regulations will be dealt with by the TWIF Executive Committee and can be penalised with a fine or a ban on advertising

**Attachment 3 Pictorial example advertisement**

**EXAMPLE OF ADVERTISEMENT AREAS ON SHIRTS AND SHORTS**

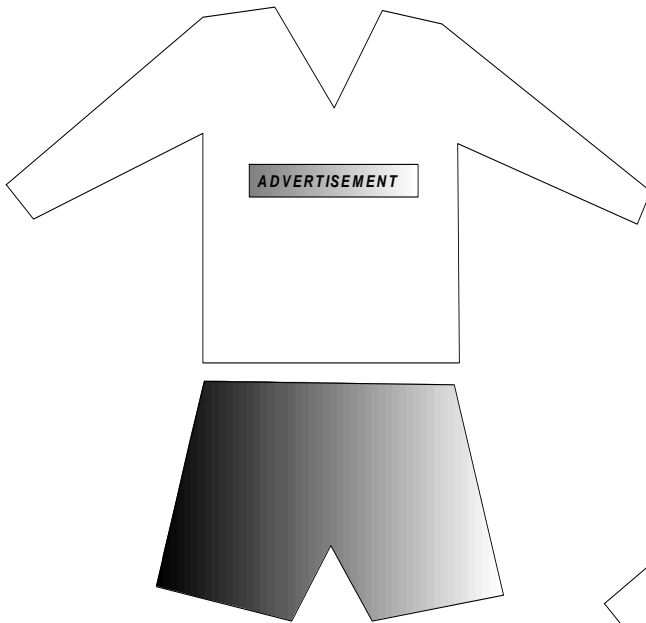

LETTER HEIGHT 10 CM

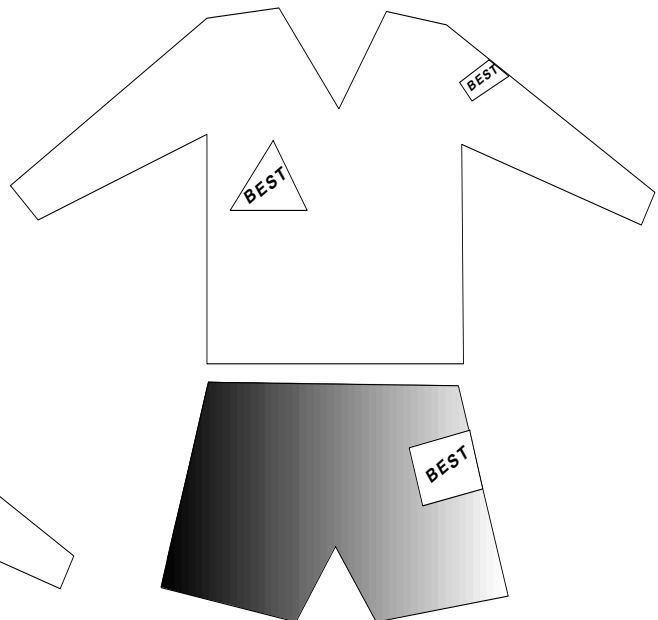

MAX THREE AREAS TOTAL 150 CM<sup>2</sup>



ONE AREA MAX 300 CM<sup>2</sup>

# **TWIF OFFICIALS**

## ***TERMS OF REFERENCE COMMITTEES / COMMISSIONS***

---

### **1 THE EXECUTIVE COMMITTEE**

The members of the Committee are elected by Congress and appointed to act as the Executive.

#### **1.1. COMPOSITION**

(Ref. article 11 TWIF Constitution)

The following officials shall be elected by the Members and appointed to act as the Executive:

- President
- Senior Vice President
- Vice President
- Secretary General
- Treasurer

#### **1.2. TERM OF OFFICE**

(Ref. article 11 TWIF Constitution)

The duration of their appointment is four years. After this period the officials can be re-elected by Congress. When, during the period mentioned in paragraph 2 of this Article, an official resigns from the Executive or is no longer available to act as an official, the Executive may appoint an official to act in the vacant office for the duration of the period until the next Annual Congress.

#### **1.3. TASK**

(Ref. article 12 TWIF Constitution)

The Executive Committee is the Administrative Body of TWIF. It manages the affairs of TWIF according to the Rules. It has to report its activities to the Annual Congress, which it has to prepare also. It represents TWIF at all occasions. The Executive can appoint ad interim officials in case of resignation of officials.

The Executive proposes the assignment of a Legal Advisor and/or Arbitrators, if necessary. The assignment of the legal advisor and arbitrators shall be approved by Congress. The Executive can, when needed for a special task or liaison; co-opt up to a maximum of two (2) officials, whose term of office will end on the termination of the special task or liaison.

#### **1.4. MEETING**

The Executive Committee meets at the following occasions;

- at the beginning of the year
- before Congress
- at the world and/or continental championships, and
- Any other times and in a manner they deem required.

# **TWIF OFFICIALS**

## **2 TECHNICAL AND ATHLETES COMMISSION**

The Commission is an advisory body, at all times responsible to the TWIF Executive and Congress.

### **2.1 COMPOSITION**

The Commission consists of not more than ten and not less than six members, appointed by the Executive Committee, from as wide a spectrum as appropriate. Member Countries may forward names for consideration by the Executive Committee, prior to the Congress when the appointments will be made. The appointment shall be ratified in conformity with Article 13 of the TWIF Constitution. The Commission can, when necessary, invite persons to attend the meeting for special advice. Such persons can only address the Commission on request and have no voting rights

### **2.2 TERM OF OFFICE**

The term of appointment to the Commission shall be four years.

### **2.3 TASK**

The Commission shall:

- advise on all matters related to the Rules of International competition.
- advise on any aspect of Tug of War referred to it by the TWIF Executive Committee or Congress
- advise on any matter brought to the attention of the Executive Committee by a Member Association, for which the Executive Committee wishes to have the view of the Commission
- discuss any relevant matter put before the Commission by Commission members, for onward transmission to the Executive Committee
- biannually at World Championships, stage Judges Courses for Grade 1 Judges nominated by Member Associations, where sufficient nominations ensure a viable course
- in conjunction with the above mentioned Judges Courses, stage Refresher Courses for Judges from the TWIF Panel of Judges

### **2.4 MEETINGS**

The Commission will normally meet on the day before a World- or Continental Championships

The Agenda, including time and venue for the meeting will be dispatched three weeks prior to the meeting



## **TWIF OFFICIALS**

### **3 PRESS AND PUBLICITY COMMISSION**

The Commission is an advisory body, at all times responsible to the TWIF Executive and Congress.

#### **3.1 COMPOSITION**

The Commission consists of not more than five members, appointed by the Executive Committee.

#### **3.2 TERM OF OFFICE**

The term of appointment to the Commission shall be four years.

#### **3.3 TASK**

The Commission shall;

- arrange for the regular publication of the TWIF Magazine
- arrange for the editing and publishing of the TWIF website on Internet
- ensure that expenses remain within the allocated budget for press, and publicity
- advise the Executive Committee on matters of press and publicity.

#### **3.4 MEETINGS**

The Commission will normally meet at Congress and/or at World or Continental Championships.

The Agenda, including time and venue for the meeting will be dispatched three weeks prior to the meeting.

### **4 MEDICAL COMMISSION / ANTI DOPING**

The Commission is an advisory body, at all times responsible to the TWIF Executive and Congress.

#### **4.1 COMPOSITION**

The Commission consists of three members with adequate expertise in the domain of the Commission, appointed by the Executive Committee. The appointment shall be ratified in conformity with Article 13 of the TWIF Constitution.

The Commission can, when necessary, invite persons to attend the meeting for special advice. Such persons can only address the Commission on request and have no voting rights

#### **4.2 TERM OF OFFICE**

The term of appointment to the Commission shall be four years.

#### **4.3 TASK**

The Commission shall;

- advise the Executive Committee on all matters regarding doping control

## **TWIF OFFICIALS**

- arrange for the correct doping control procedure, in co-operation with the doping control authority of the host country
- report to the Executive Committee on the result of the doping control after the competition
- ensure that the correct procedure is performed in case(s) of positive test(s)
- advise the Executive Committee on any sport medical matter for which the Executive Committee has requested advice from the Commission

### **4.4 MEETINGS**

The Commission will normally meet at Congress and/or at World or Continental Championships

The Agenda, including time and venue for the meeting will be dispatched three weeks prior to the meeting.

## **5 Appeal Commission**

The Appeal Commission is responsible for hearing appeals against decisions of the Executive Committee that have not been confirmed by Congress. Composition and terms of reference are indicated in Article 21 of the TWIF Constitution.

The appointed TWIF Legal Advisor is the Chair of the Commission.

## **6 TUE (THERAPEUTIC USE EXEMPTION) Commission**

The TUE Commission (TUEC) is appointed in accordance with article 4.4.4.3. of the TWIF Anti-Doping Rules.

The TWIF TUEC, which can be outsourced and operated by a *Delegated Third Party*, shall consist of a minimum of five (5) members with experience in the care and treatment of Athletes and sound knowledge of clinical, sports and exercise medicine. Each appointed member should serve a term of four (4) years which is renewable

Before serving as a member of the TWIF TUEC, each member must sign a conflict of interest and confidentiality declaration. The appointed members shall not be employees of TWIF.

When an application to TWIF for the grant or recognition of a *TUE* is made, the Chair of the TWIF TUEC shall appoint three (3) members (which may include the Chair) to consider the application.

# TWIF OFFICIALS

## OFFICIALS INTERNATIONAL COMPETITIONS

---

*Note: The Controller, Referee and Chief Judge have, in in coordination with each other, the power to expel teams and/or individual from participating in an event in accordance with Powers of Officials as indicated page 36*

### 1 CONTROLLER

The Controller is responsible for the overall running of events and works in close liaison with the Chief Judge and Referee. The Controller will normally be the Secretary General of TWIF

#### 1.1 TASK

The Controller shall:

- examine, before commencing an event, the Weigh-in Forms of the teams entered for the event, presented to him by the Weigh master, in order to check that the teams have passed the scales and signed the appropriate section, committing the team to strict adherence to the TWIF Rules for Competition.
- ensure that full information is announced by public address system throughout the event, giving particular emphasis to changes in timing of the start of a particular weight class and ensure that teams entered such weight class are fully aware of such changes
- ensure that Draw Sheets are distributed to TWIF Officials (officiating Judges, Marshal's and Timekeeper/Recorders) and team coaches in the event
- ensure that Medals and Awards are available for presentation and that teams and spectators are informed of the time of the presentation.
- select Timekeeper/Recorders for World and Continental Championships
- brief the Timekeeper/Recorders prior to the competitions.

### 2 REFEREE

The Referee is responsible to deal with matters of dispute and undiscipline not related to the pulling and works in close liaison with the Controller and the Chief Judge. The Referee will not officiate as Judge at any of the competitions

#### 2.1 TASK

The Referee shall:

- ensure that complainant(s) present any major issue of dispute in writing, stating the nature of the complaint and in the case of breach of the TWIF Rules, the relevant rule or directive
- ensure that appointed Stewards will keep unauthorized persons outside the pulling arena whilst the competition is in progress
- assist the Chief Judge in ensuring that all competition are completed with minimum delay
- confirm, in consultation with the Chief Judge, the necessity to move the rope to fresh ground, when appropriate.

# TWIF OFFICIALS

## 3 CHIEF JUDGE

The Chief Judge has authority over the entire pulling arena and works in close liaison with the Controller and the Referee.

### 3.1 TASK

The Chief Judge shall;

- arrange the 'lay-out' of all ropes for competition and ensure that the ropes are correctly marked
  - brief all Judges and Marshals prior to the competition
  - allocate Judges their respective ropes in competition
  - deal with matters of dispute and indiscipline related to pulling and refer all other matters of dispute or indiscipline to the Referee
  - arrange breaks for officiating Judges to leave the arena for a meal
  - decide to move ropes to fresh grounds when appropriate
- ensure that Marshals have teams lined up at the entrance of the arena in time and ready for the competition

## 4 WEIGHMASTER

(ref. article 25 TWIF Rules)

In international competitions, stewards may be appointed by TWIF who shall be responsible to the Weigh master (judge in charge of the weigh-in) for correctly weighing and stamping all competitors.

The Weigh master is responsible for all weigh-in matters and works in close liaison with the Controller and Chief Judge

### 4.1 TASK

The Weigh master shall;

- check the accuracy of the (digital/electronic)scales
- arrange, in consultation with the host country, the setting up of the scales
- provide the stamps for marking of the competitors
- appoint Judges to assist at the weigh-in
- allocate Judges to scales as well as Judges to check the competitors boots
- arrange that the teams are marshalled to the scales
- ensure that team coaches sign the appropriate section of the Weigh-in Form, committing the team to compete in strict adherence to the TWI F Rules
- check, where appropriate, the passport of the competitor to confirm age
- inform the Chief Judge on the marks on the competitors legs and/or arms
- ensure that all Weigh-in Forms have been handed to the Controller
- take decisions, in case of dispute between competitor and Judge checking the boots
- note the name(s) of competitors whose boots have been determined to be illegal and ensure that they will be rechecked before starting the competition
- consult the Referee in case boots are still illegal after rechecking at the start of the competition
- close the scales at the appointed time
- consult with Controller and Chief Judge when there are mitigating circumstances which merit weigh-in of (a) teams(s) after the scales are closed.

# TWIF OFFICIALS

## 5 CHIEF MARSHAL

The Chief Marshal shall ensure that throughout the competition, teams are timely assembled at the entry point(s) of the arena ready to march with the judges in charge to the rope

### 5.1 TASK

The Chief Marshal shall:

- Attend all briefings.
- Approach organisers and appoint Marshals.
- Co-ordinate with the Controller and the Chief Judge prior to the start of the competition to arrange the order of the competition.
- Brief Marshals before the start of the competition and allocate them to their respective marshalling corners / areas
- Appoint one Marshal to be in charge of each corner / area.
- Issue bibs to Marshals and collect the bibs at the close of each day of competition.
- Liaise with the Controller and the Chief Judge throughout the competition to ensure smooth running of the programme.
- Distribute draw sheets to each corner / area.
- Arrange that athletes are marshalled to the scales during weigh-ins
- Ensure all teams are marshalled ready for prompt start of competition.
- Liaise with Control and Organisers to have necessary teams ready for Parade and Presentations.
- Organise teams in marshalling area for the pull-offs and finals in co-ordination with the Chief Judge.
- Inform the Controller throughout the competition – of the instructions of the Chief Judge on what ropes are to be used and where pull-offs are to take place.

## 6 JUDGES

(ref. article 22 TWIF Rules)

The final selection of judges for international competition shall be the responsibility of the Technical and Athletes Commission.

### 6.1 TASK CENTRE JUDGE

(ref. article 24 TWIF Rules)

The appointed judge for a match shall have sole control.

He/She shall be responsible for ensuring:

- that the Rules of "TWIF" are adhered to
  - that the rope is laid out ready for competition before the teams arrive in the pulling area
  - that, as far as possible, the pre-determined timetable is adhered to.
- He/She has the power to;
- grant rest periods as shown in Rule 17
  - declare a "No pull"
  - disqualify a team or teams after caution.
  - disqualify a team without caution which he deems to be guilty of ungentlemanly conduct, by word or act, which is likely to bring the sport into disrepute.

## **TWIF OFFICIALS**

In the event of the judge in charge giving a caution, which he will indicate by the common signal code, naming the team and adding "first caution" or "last caution". Any such instructions given by the judge in charge must be clear and brief using the appropriate signals.

The judge's decision shall be final at all times subject to a review by the Executive, Competition Manager, Chief Judge and Chief Recorder if an immediate challenge has been lodged.

### **6.2 TASK SIDE JUDGE**

(ref. article 25 TWIF Rules)

Side judges shall at all times act under the directions of the judge in charge. During the actual pulling the side judge shall take up a position alongside the competing teams and to the opposite side of the judge in charge. The side judge shall observe the competing teams and indicate the infringements of the teams to the judge in charge, using the common signal code. The side judge will inform the offenders of the cautions given by the judge in charge.

## **7 CHIEF TIMEKEEPER/RECORDER**

The Chief Timekeeper/Recorder is directly responsible to the Controller. The Chief Timekeeper/ Recorder will be responsible for all the other timekeeper/recorders. Assisting should they experience any difficulties. Also ensure that the results are recorded correctly either by use of computer and / or legibly by hand.

### **7.1 TASK**

- Attend all briefings and at the conclusion of the main briefing, be responsible for gathering the timekeeper/recorders together, and with the Controller, brief them on the requirements.
- Liaise with the Controller, on all aspects of the competition. Jointly making the decision on how many timekeeper/recorders will be required for weigh-in as well as the competition start. Check the start time of the competition, and decide with the Controller what time timekeeper/recorders should report to the Arena/Hall. Including nominating personnel for duties on the field to collect Judge's caution cards.
- Ensure that sufficient recording sheets are available for timekeeper/recorders in plenty of time before the start of each competition and each weight class. Also ensure that copies of draw sheets have been given to all other officials.
- Should confusion arise regarding cautions, be ready to immediately confirm with the judge regarding their given cautions on any pull. Delay will only add to the confusion. This action must be taken immediately.
- Ensure that timekeeper/recorders are given 'space and time' when the criteria/call-back system had to be implemented.
- Nearing the end of the competition, ensure that sufficient, pull-off sheets, final sheets and placing sheets are available for timekeeper/recorders. Confirm which ropes these matches will appear on with the Chief Judge or Controller via headset or handset. Ensure that each timekeeper/recorder is fully aware of which match/matches and which rope/ropes will be used.
- Ensure that Control has a full list of placing, for the medal presentations.

## TWIF OFFICIALS

- At the end of the competition ensure the results are thoroughly checked before going to admin for inclusion onto disk or into a result book. Also collect each timekeeper/recorder's set of result sheets and place in a folder for future reference, and give to the Controller.

### 8. TIMEKEEPER/RECORDER

The Timekeeper/Recorder keeps record during the competition of the results of the teams and has full knowledge of relevant sections of the TWIF Rules for International Competitions. The task of recording can be done by one individual or by a pair of two timekeeper/recorders. The Timekeeper/Recorders are responsible to the Chief Timekeeper/Recorder and Controller.

#### 8.1 TASK

The Timekeeper/Recorder shall:

- *after the weigh-in* when so requested assist the Controller with;
  - checking the weigh-in sheets
  - input names of teams in computer programme or on appropriate draw sheets when no computer programme is available
  - copying draw sheets for the competition for the Judges, Marshals, Team Coaches and Timekeeper/Recorders.
- *during the competition* when so requested assist the Controller with;
  - preparing a list of results in readiness for the presentation of medals/awards.
  - preparing master copy of the results for the organisers for preparation for the result book.
- report to the Controller at least fifteen to twenty minutes before the competition starts.
- on receipt of the appropriate score sheet report to the allocated recording area.
- once the competition starts record on the score sheet in the appropriate places
  - the times of each pull
  - the cautions accrued
  - the score at the end of the match
- during the competition keep the score table and the caution table of the TWIF score sheet up to date so at the end of the competition the results can be given to the Chief Timekeeper/Recorder or Controller as soon as possible.
- during the competition, if necessary, record the times of teams coming off their rope at the end of the match, to check the rest period and liaise with the judge and advise accordingly.
- at the end of the qualifying round check the points scored by each team and list the teams in order of placing and advise the Chief Timekeeper/Recorder or Controller on the teams to go forward to the pull-offs
- have applicable details available in case there are teams on equal points and the ranking criteria have to be applied.
- hand the score sheets to the Chief Timekeeper/Recorder or Controller at the end of each competition
- prepare the score sheets for the pull-offs and once the competition is finished pass the results to the Chief Timekeeper/Recorder or Controller.

## TWIF OFFICIALS

### 9. JUDGES' DRESS CODE:

The appropriate TWIF Judges uniform comprises of a softshell, shirt, hat & badge **BLACK** dress trousers (see illustration below) must also be worn.





## ***TWIF JUDGES PANEL***

---

### **1 THE PANEL**

The TWIF Panel of Judges is a list of qualified international judges. The judges officiating at international championships will be selected from this list.

### **2 QUALIFICATION TO BE INCLUDED IN THE TWIF JUDGES PANEL**

Before inclusion in the TWIF Panel of Judges, the judges will have to qualify during an official TWIF Judges course with an overall result of 85 percent in the examination. A Judge will remain on the panel until they decide to retire, they do not pass the refresher course or fail the evaluation criteria (see below).

### **3 Twif Qualified Judges.**

Twif qualified Judges will be assigned to three categories as follows;

- a) Both Indoor and Outdoor, or
- b) Outdoor only, or
- c) Indoor only

### **4 TWIF JUDGES COURSE**

National judges will be qualified by a grading system of their national association. The grading consists of three levels, Grade 3, 2 and 1. (Grade 1 is the highest level) Each member association of TWIF can nominate national Grade 1 judges for participation in a TWIF Judges Course. When a member association nominates a national grade one judge for the course they MUST submit, in detail, their national association grading system for assessment by TWIF. If this fails to meet the requirement the Judge may not be permitted to attend the course. That to be eligible to sit the TWIF Judges course, Judges must be able to demonstrate, with suitable evidence, that they have a minimum of 6 years judging experience. This experience should include Judging at regular competitions throughout the period and Judging at National Championships. A TWIF Judges Course consists of a session at which the national judges will be instructed on the required international interpretation and implementation of the TWIF Rules for Tug of War. The examination consists of a written examination, as well as a practical test during international competition.

### **5 REFRESHER COURSES**

At each TWIF Judges course a maximum of ten (10) judges from the TWIF Panel of Judges shall retake the TWIF Judges course. The judges from the TWIF Panel of Judges shall be invited by rotation, so all judges on the Panel will be given the opportunity to enhance and improve their judging proficiency. TWIF judges failing to attend the Refresher Course without acceptable justification and TWIF Judges not qualifying in the examination of the Refresher Course will be removed from the TWIF Panel of Judges. In case a TWIF judge, for justifiable reason, is unable to attend a Refresher Course he/ she will take the next available Refresher Course. The maximum period between Refresher Courses for a Judge is six years.

## **6 CRITIQUE**

During TWIF Championships, each and every TWIF Judge will be observed by a qualified person. Instantly after the observation, the judge will be informed on his/her achievement in judging, with the aim to improve the proficiency and performance of the judge. The observer shall be appointed by the TWIF Executive in consultation with the Technical Commission.

## **7 EVALUATION OF JUDGES**

Each TWIF judge will be evaluated during their judging in the championships by three appointed TWIF evaluators. The evaluators will be appointed by the TWIF Executive in consultation with the Technical Commission. The evaluation report will indicate whether the performance of the Judge is in conformity with the required standard or is below standard. The TWIF Judges will be informed on the result of the evaluation by the evaluators. In case a TWIF Judge has been evaluated three times with a proficiency result below standard, he/she will be removed from the Panel of TWIF Judges.

## **TIMEKEEPER RECORDERS PANEL**

---

### **1 THE PANEL**

The TWIF Panel of Timekeeper/Recorders is a list of qualified international recorders.

### **2 QUALIFICATION TO BE INCLUDED IN THE TWIF TIMEKEEPER/RECORDERS PANEL**

Before the inclusion in the TWIF Panel of Timekeeper/Recorders, the timekeeper/recorders will have to qualify during an official TWIF Timekeeper/Recorders course

### **3 TWIF TIMEKEEPER/RECORDERS COURSE**

TWIF has held a number of Timekeeper/Recorders Courses

Future courses will also focus on using computer programmes for recording competition results

### **4 REFRESHER COURSE**

In future these courses might be organized to ensure the required proficiency of the timekeeper/recorders officiating at the event.

### **5 TIMEKEEPER/ RECORDER DRESS CODE**

The appropriate TWIF Timekeepers and Recorders Uniform comprises of a jacket (softshell), polo shirt, black trousers or skirt and sensible black shoes.